

500KG ELECTRIC DOUBLE SCISSOR LIFT TROLLEY



The Electric Double Scissor Lift has a load capacity of 500kg and has the ability to reach higher areas than single scissor lifts. This double scissor lift is designed for indoor and outdoor environments such as warehouses and construction sites. Our range of electric scissor lifts are easy to use due to their control box that is operated with push buttons.

GENERAL INFO & FEATURES

- Capacity: 500 kg
- Stroke: 1123 mm
- Lift height: 495 - 1618 mm
- Table size: L1010 x W520 mm
- Electric lift via battery power
- Mobile on 2 fixes & 2 swivel castors
- Handle mounted push buttons
- Charging cable & display included
- Hose burst valves

SPECIFICATION

Specification

- Lifting time: 12 seconds
- Platform size: L1010 x W520mm
- 12V battery

Recommended use

- Building sites
- Warehouses
- Construction environments

Key features

- CE Marked
- Made to order
- Complies with EN 1570-1 requirements

DIMENSIONS



SKU	Capacity	Height	Length	Lifting Capacity	Lift Height	Options	Type	Width
10320069	500kg	495mm	1010mm	500kg	1618mm	Double	Mobile	520mm

TECHNICAL DRAWINGS

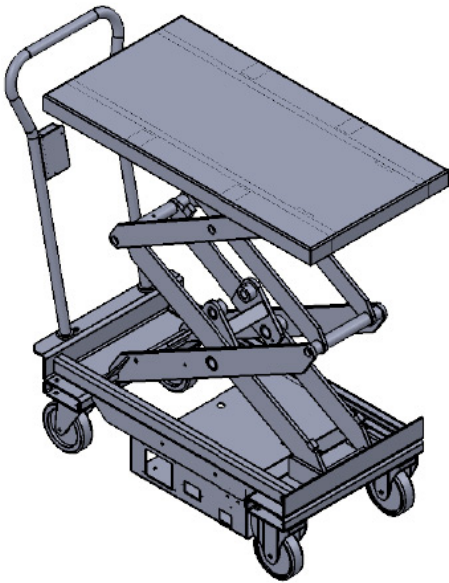

BIRDS EYE VIEW

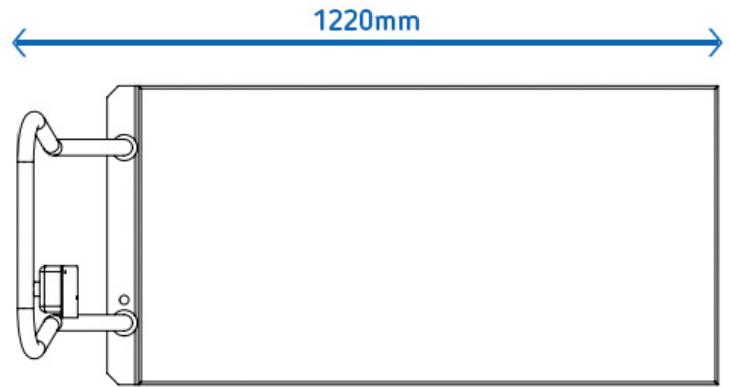

FRONT AND SIDE VIEW

